

### 2-POLE – GPS/ISM915

### DIMENSIONS: mm

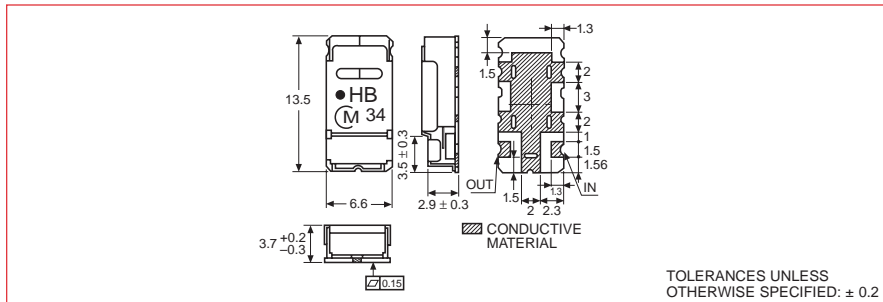

### TRANSMISSION vs. REFLECTION CHARACTERISTICS

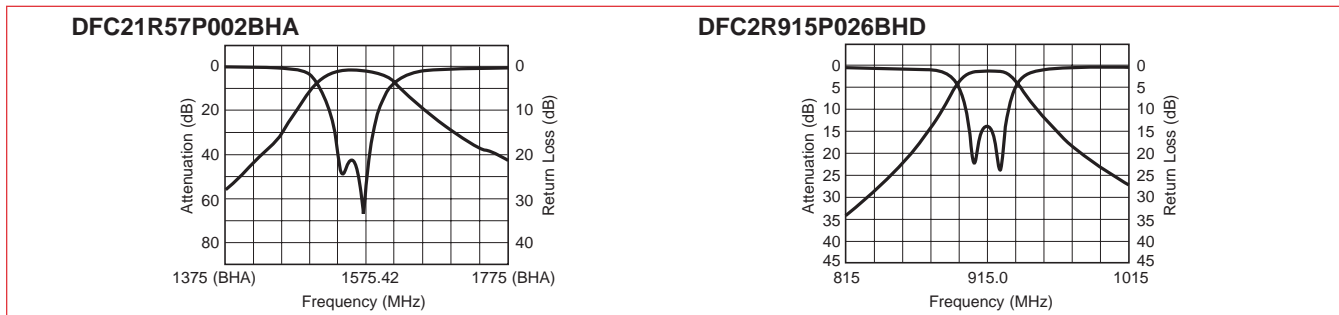

### SPECIFICATIONS

Type	Part Number	Center Frequency fo (MHz)	Bandwidth (MHz)	Insertion Loss in BW (dB)	Ripple in BW (dB)	V.S.W.R. in BW	Attenuation (dB) (MHz)	Marking
GPS	DFC21R57P002BHA	1575.42	fo ± 1.0	0.8 (+25°C)	0.3	2.0	16 (fo - 140)	HB
				0.9 (-30 ~ +85°C)			14 (fo + 140)	
ISM915	DFC2R915P026BHD	915.0	fo ± 13.0	2.3	1.0	2.0	23 (fo - 77.5) 18 (fo + 77.5)	GB

### 2-POLE – ISM 2.4GHZ/GPS

### DIMENSIONS: mm

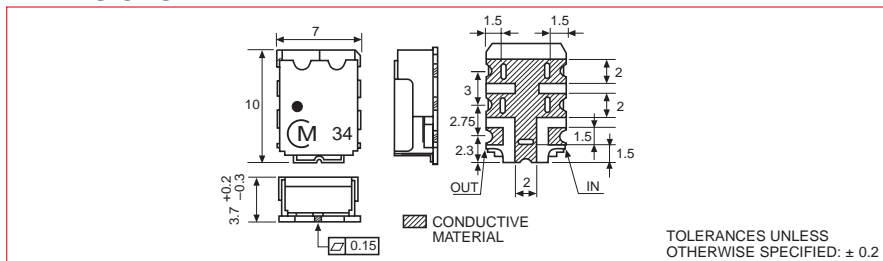

### TRANSMISSION vs. REFLECTION CHARACTERISTICS

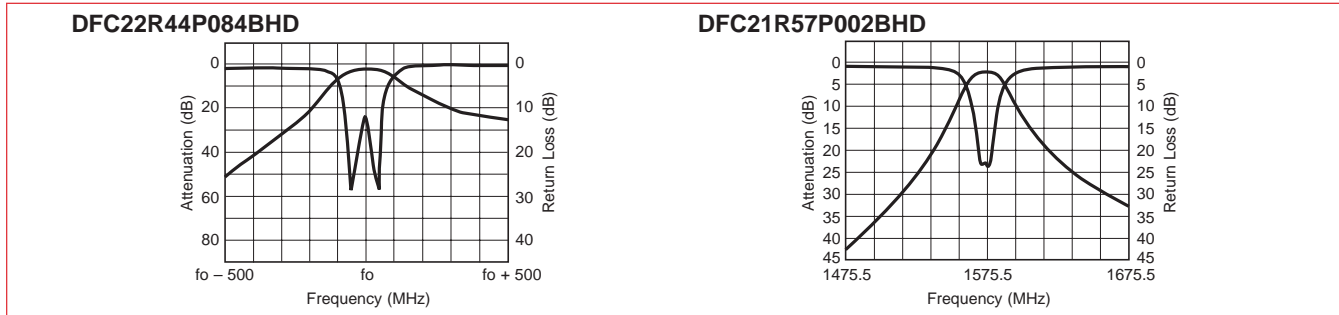

### SPECIFICATIONS

Type	Part Number	Center Frequency fo (MHz)	Bandwidth (MHz)	Insertion Loss in BW (dB)	Ripple in BW (dB)	V.S.W.R. in BW	Attenuation (dB) (MHz)	Marking
ISM 2.4GHz	DFC22R44P084BHD	2442.0	fo ± 42.0	1.0 (+25°C)	0.5	2.0	15 (fo ± 250)	GC
				1.2 (-35 ~ +85°C)				
GPS	DFC21R57P002BHD	1575.5	fo ± 1.0	3.0	0.5	2.0	12 (fo - 30)	GD
							11 (fo + 30)	
							22 (fo - 50)	
							18 (fo + 50)	

#### 3-POLE—ISM 2.4GHz/M-SAT



#### DIMENSIONS: mm

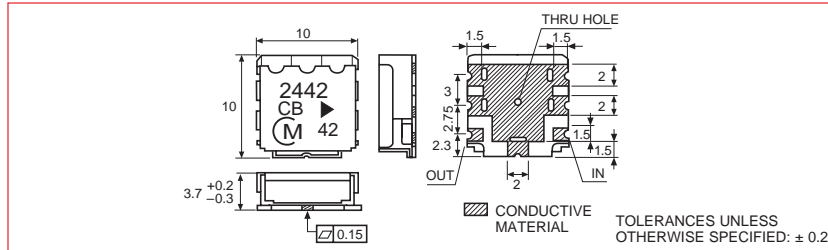

#### TRANSMISSION vs. REFLECTION CHARACTERISTICS

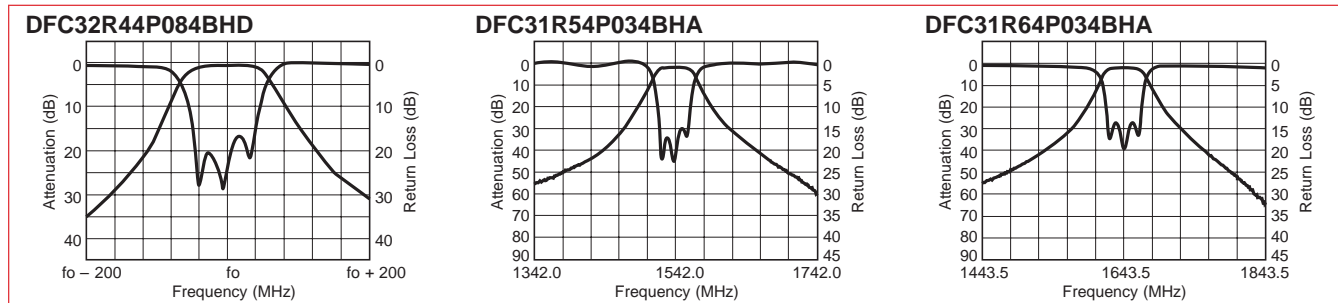

#### SPECIFICATIONS

Type	Part Number	Center Frequency $f_0$ (MHz)	Bandwidth (MHz)	Insertion Loss in BW (dB)	Ripple in BW (dB)	V.S.W.R. in BW	Attenuation (dB) (MHz)	Marking
ISM 2.4GHz	DFC32R44P084BHD	2442.0	$f_0 \pm 42.0$	2.0 (0 ~ +85°C)	1.0	2.0	6 ( $f_0 \pm 80$ )	2442 CB
				2.4 (-30 ~ +85°C)				
M-SAT	DFC31R54P034BHA	1542.0	$f_0 \pm 17$	3.0	0.9	2.0	30 (1626.5 – 1660.5)	1643 CC
	DFC31R64P034BHA	1643.5			0.7		30 (1525 – 1559)	

#### 3-POLE—E-AMPS/GSM/SMR/ISM915

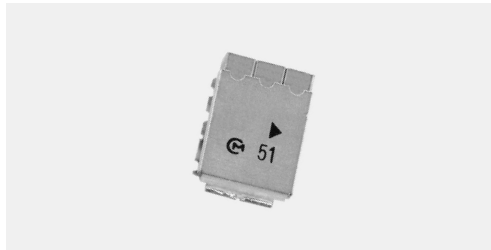

#### DIMENSIONS: mm

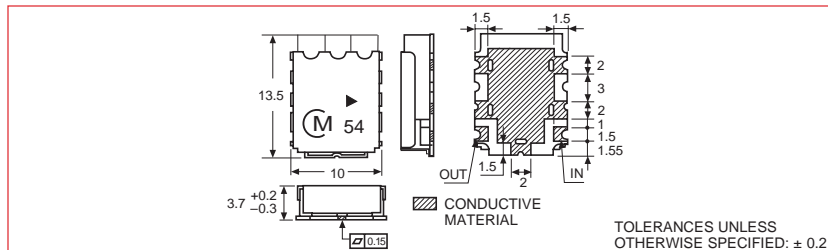

#### TRANSMISSION vs. REFLECTION CHARACTERISTICS

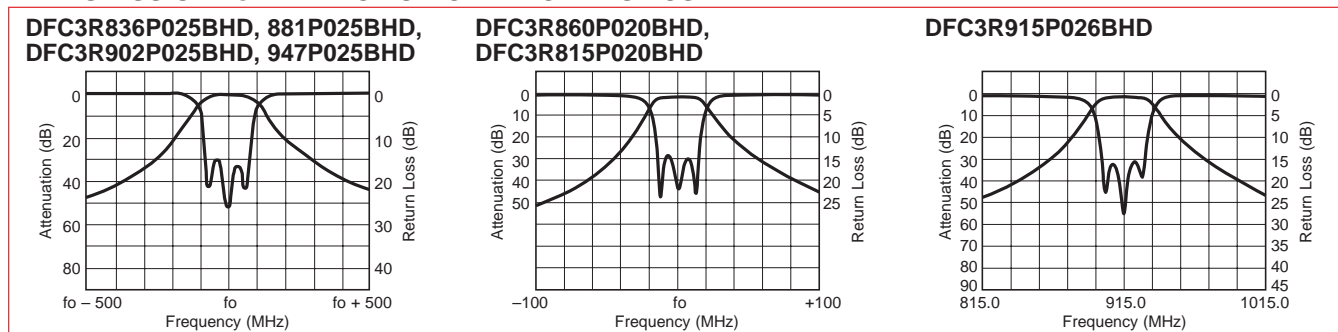

#### SPECIFICATIONS

Type	Part Number	Center Frequency $f_0$ (MHz)	Bandwidth (MHz)	Insertion Loss in BW (dB)	Ripple in BW (dB)	V.S.W.R. in BW	Attenuation (dB) (MHz)	Marking
E-AMPS	DFC3R836P025BHD	836.5	$f_0 \pm 12.5$	2.6	1.0	2.0	12 ( $f_0 \pm 32.5$ )	836 CC
	DFC3R881P025BHD	881.5	$f_0 \pm 12.5$	2.6	1.0	2.0	12 ( $f_0 \pm 32.5$ )	881 CA
GSM	DFC3R902P025BHD	902.5	$f_0 \pm 12.5$	2.6	1.0	2.0	12 ( $f_0 \pm 32.5$ )	902 CC
	DFC3R947P025BHD	947.5	$f_0 \pm 12.5$	2.6	1.0	2.0	12 ( $f_0 \pm 32.5$ )	947 CD
ISM915	DFC3R915P026BHD	915.0	$f_0 \pm 13$	3.0	1.0	2.0	12 ( $f_0 \pm 32.5$ )	915 CD
SMR	DFC3R815P020BHD	815	$f_0 \pm 10$	2.8	0.8	2.0	36 (860 ± 10)	815 CB
	DFC3R860P020BHD	860	$f_0 \pm 10$	2.8	0.8	2.0	36 (815 ± 10)	860 CC

# CERAMIC MICROWAVE FILTERS

## BAND PASS FILTERS—DP TYPE

### SMD-3-POLE-PCS/DCS 1800

### DIMENSIONS: mm

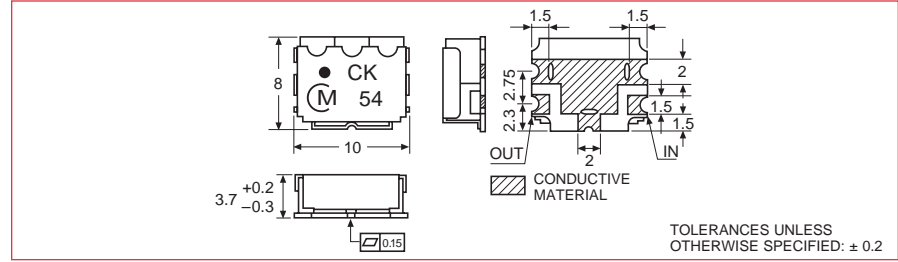

### TRANSMISSION vs. REFLECTION CHARACTERISTICS

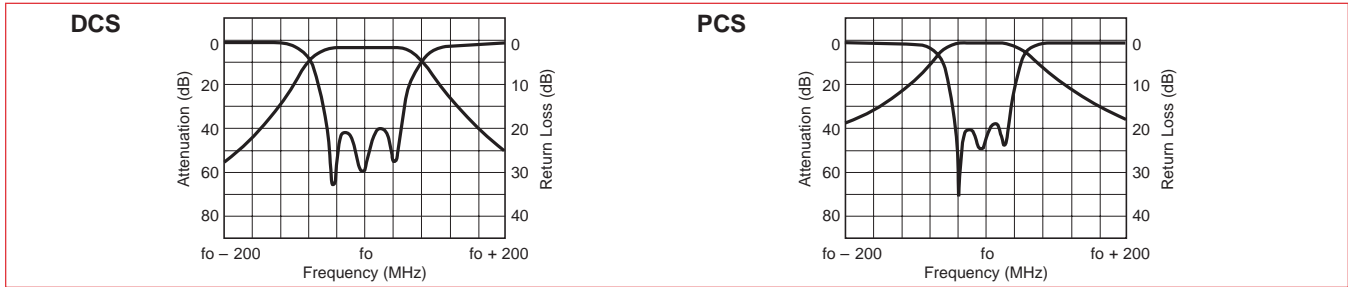

### SPECIFICATIONS

Type	Part Number	Center Frequency fo (MHz)	Bandwidth (MHz)	Insertion Loss in BW (dB)	Ripple in BW (dB)	V.S.W.R. in BW	Attenuation (dB) (MHz)	Marking
DCS	DFC31R74P075BHD	1747.5	fo ± 37.5	2.0	1.0	2.0	8 (fo ± 80) 25 (fo ± 160)	CH
	DFC31R84P075BHD	1842.5	fo ± 37.5	2.0	0.8	2.0	8 (fo ± 80) 25 (fo ± 160)	CG
PCS	DFC31R88P060BHD	1880	fo ± 30	2.2	0.8	1.8	15 (fo ± 100)	CK
	DFC31R96P060BHD	1960	fo ± 30	2.2	0.8	1.8	48 (fo ± 400)	CL

### 4-POLE-PCS

### DIMENSIONS: mm

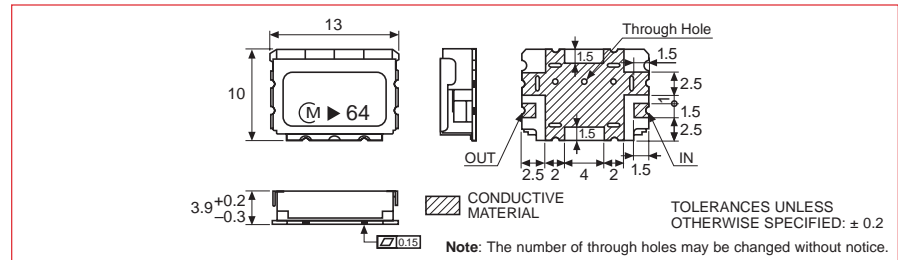

### TRANSMISSION vs. REFLECTION CHARACTERISTICS

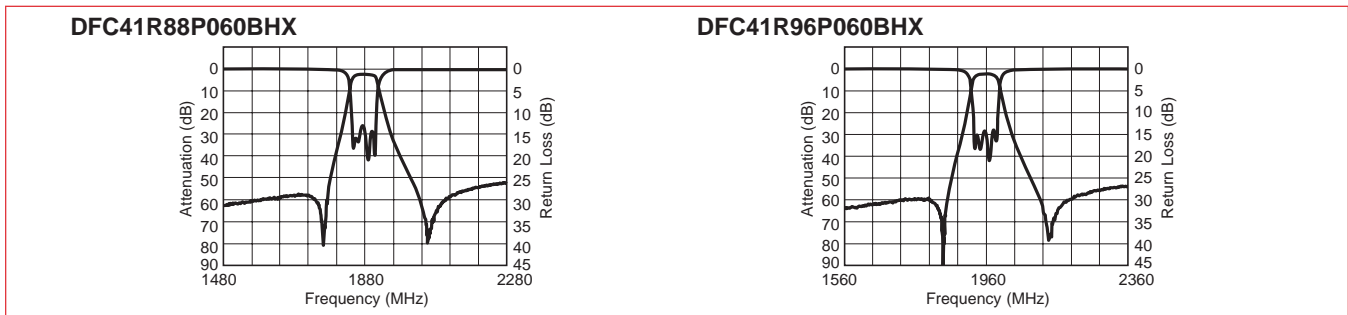

### SPECIFICATIONS

Type	Part Number	Center Frequency fo (MHz)	Bandwidth (MHz)	Insertion Loss in BW (dB)	Ripple in BW (dB)	V.S.W.R. in BW	Attenuation (dB) (MHz)	Marking
PCS	DFC41R88P060BHX	1880	fo ± 30	4.5	1.4	2.0	12 (fo ± 50)	1880 DA
							30 (fo ± 100)	
							50 (fo ± 200)	
PCS	DFC41R96P060BHX	1960	fo ± 30	4.5	1.4	2.0	12 (fo ± 50)	1960 DG
							30 (fo ± 100)	
							50 (fo ± 200)	

**DP TYPE/GPS-2-POLE**

DFC21R57P002BHA  
DFC2R915P026BHD

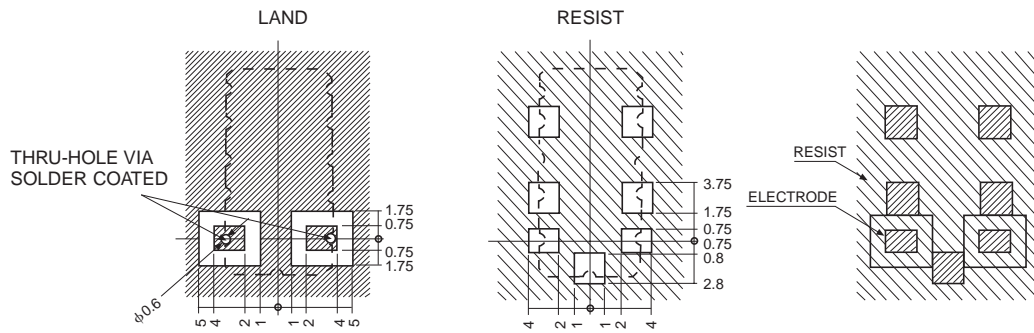

**DP TYPE/ISM 2.4GHM-2-POLE**

DFC22R44P084BHD  
DFC21R57P002BHD

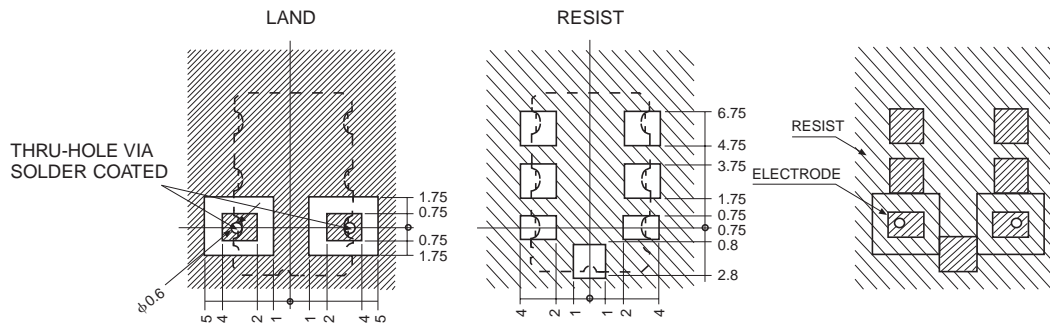

**DP TYPE/ISM 2.4GHM-3-POLE**

DFC32R44P084BHD  
DFC31R54P034BHA  
DFC31R64P034BHA

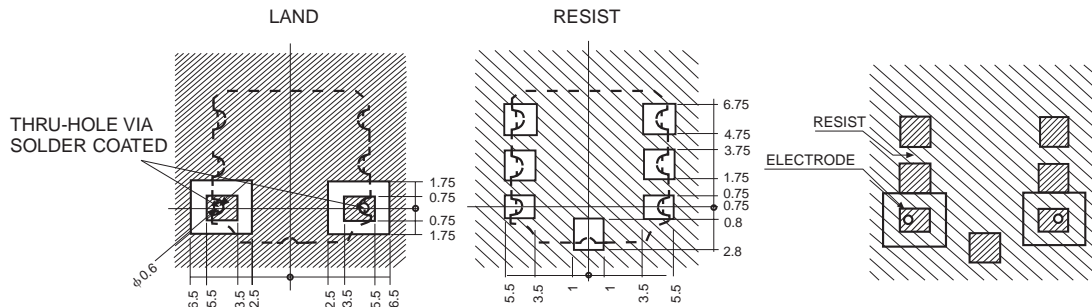

CERAMIC MICROWAVE FILTERS

#### DP TYPE /E-AMPS/GSM/EGSM/E-TACS – 3-POLE

DFC3R836P025BHD    DFC3R915P026BHD  
 DFC3R881P025BHD    DFC3R815P020BHD  
 DFC3R902P025BHD    DFC3R860P020BHD  
 DFC3R947P025BHD  
 DFC3R888P033BHD  
 DFC3R933P033BHD

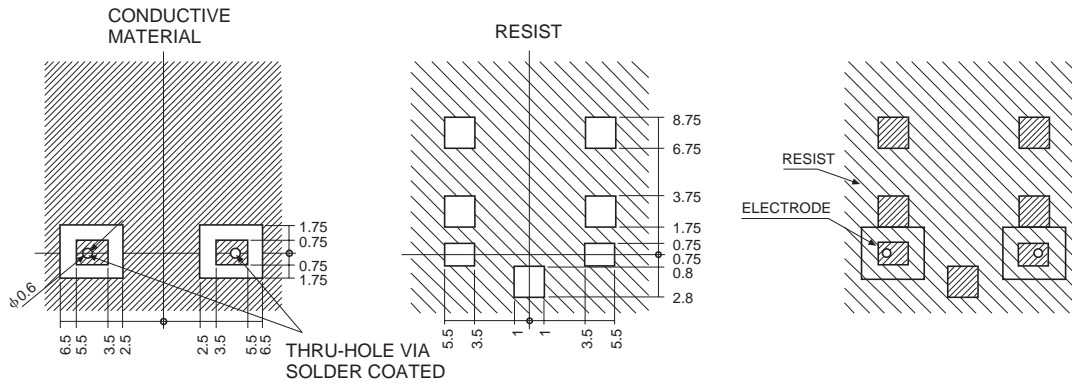

#### DP TYPE /PCS/DCS 1800 – 3-POLE

DFC31R74P075BHD  
 DFC31R84P075BHD  
 DFC31R88P060BHD  
 DFC31R96P060BHD

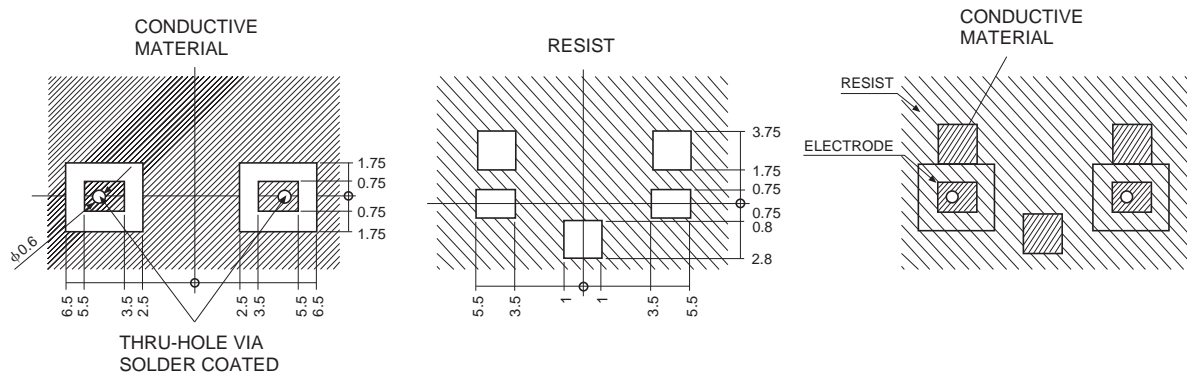

#### ALSO AVAILABLE:

Application	Part Number 2-Pole	Marking	Application	Part Number 3-Pole	Marking	Application	Part Number 4-Pole	Marking
GSM	DFC2R902E025BHD	BP	EGSM	DFC3R897P035BHD	897 CB	EGSM	DFC4R897P035BHD	897 DA
				DFC3R942P035BHD	942 CA		DFC4R942P035BHD	942 DA
			GSM	DFC4R902P025BHA	902 DA	DCS 1800	DFC41R74P075BHx	1747 DC
				DFC4R947P025BHA	947 DA		DFC41R84P075BHx	1842 DG
			MDS	DFC32R15P020BHD	2156 CA	MMDS	DFC42R59P186BHD	2593 DB

#### 2-POLE—LOW COST

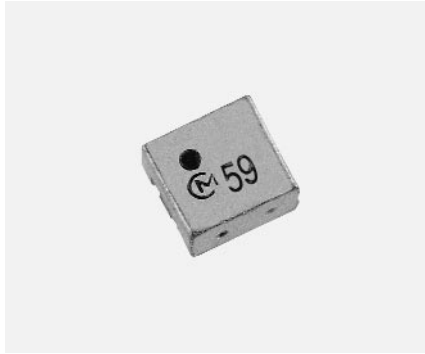

#### DIMENSIONS: mm

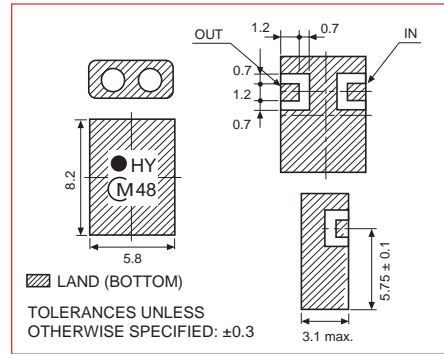

#### TRANSMISSION vs. REFLECTION CHARACTERISTICS

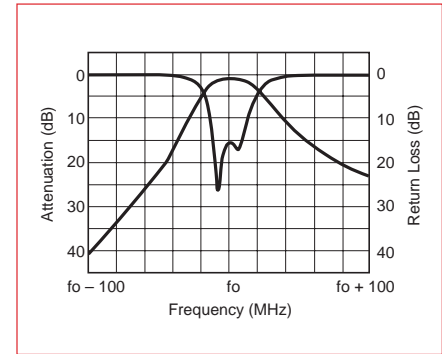

#### SPECIFICATIONS E-AMPS/ISM/GSM

Part Number	Center Frequency fo (MHz)	Bandwidth (MHz)	Insertion Loss in BW (dB)	Ripple in BW (dB)	V.S.W.R. in BW	Attenuation (dB) (MHz)	Marking
DFC2R836P025HHD	836.5	fo ± 12.5	2.6	1.2	2.3	6.5 (869 ~ 894)	HY
DFC2R881P025HHD	881.5	fo ± 12.5	2.6	1.2	2.3	9 (824 ~ 849)	HZ
DFC2R915P026HHE	915.0	fo ± 13	2.6	1.0	2.0	17 (992.5)	JV
DFC2R902P025HHD	902.5	fo ± 12.5	2.6	1.2	2.3	6.5 (935 ~ 960)	JW
DFC2R947P025HHD	947.5	fo ± 12.5	2.6	1.2	2.3	9 (890 ~ 915)	JX

#### 2-POLE

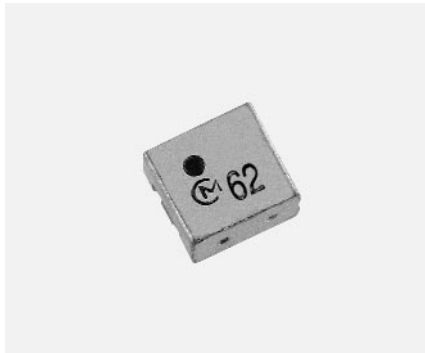

#### DIMENSIONS: mm

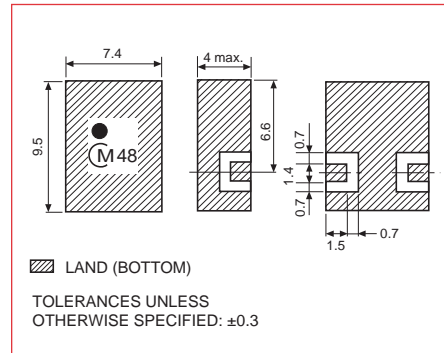

#### TRANSMISSION vs. REFLECTION CHARACTERISTICS

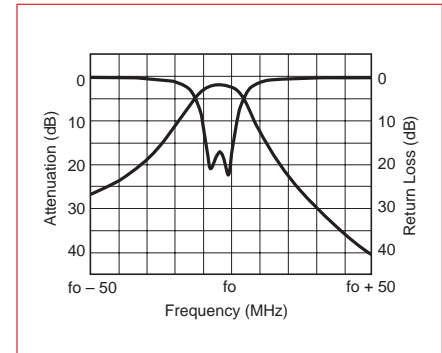

#### SPECIFICATIONS ISM 903/927

Part Number	Center Frequency fo (MHz)	Bandwidth (MHz)	Insertion Loss in BW (dB)	Ripple in BW (dB)	V.S.W.R. in BW	Attenuation (dB) (MHz)	Marking
DFC2R903P002HHA	903.0	fo ± 1	3.0	0.5	2.0	20 (fo ± 22)	903 BC
DFC2R927P002HHA	927.0	fo ± 1	3.0	0.5	2.0	15 (fo ± 22)	927 BC

### 2-POLE—PCS/DCS 1800

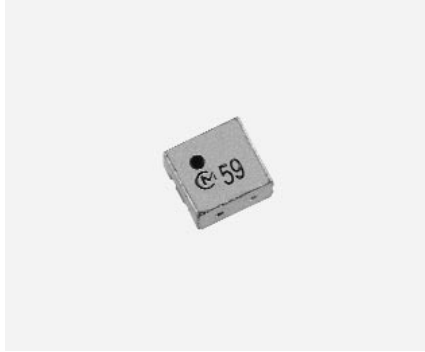

### DIMENSIONS: mm

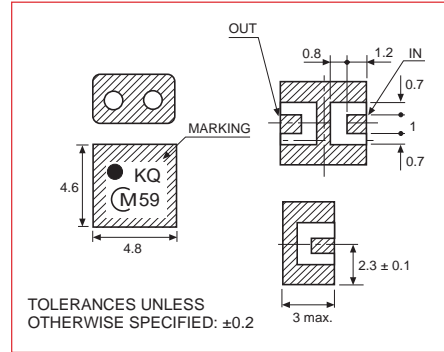

### TRANSMISSION vs. REFLECTION CHARACTERISTICS

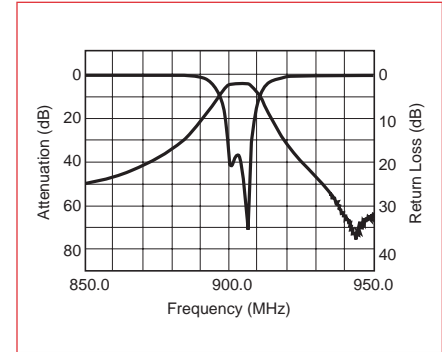

### SPECIFICATIONS

Part Number	Center Frequency fo (MHz)	Bandwidth (MHz)	Insertion Loss in BW (dB)	Ripple in BW (dB)	V.S.W.R. in BW	Attenuation (dB) (MHz)	Marking
DFC21R88P060HHA	1880	fo ± 30	2.6	1.2	2.3	17 (fo + 100)	KW
DFC21R96P060HHA	1960	fo ± 30	2.6	1.2	2.3	40 (fo - 400)	KX
DFC21R74P075HHA	1745	fo ± 37.5	2.0	1.0	2.0	10 (1907.5)	KN
DFC21R84P075HHA	1845	fo ± 37.5	2.0	1.0	2.0	20 (1682.5)	KQ

### 2-POLE—ISM 2.4GHz



### DIMENSIONS: mm

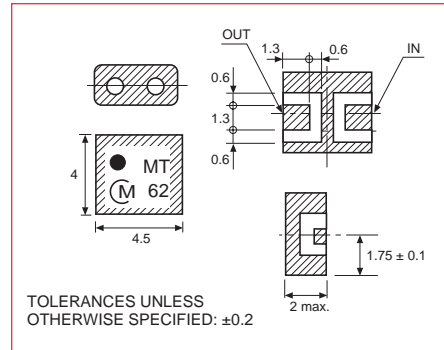

### TRANSMISSION vs. REFLECTION CHARACTERISTICS

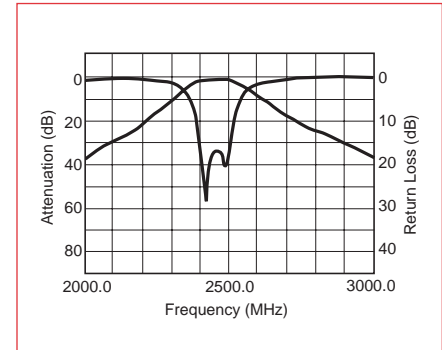

### SPECIFICATIONS

Part Number	Center Frequency fo (MHz)	Bandwidth (MHz)	Insertion Loss in BW (dB)	Ripple in BW (dB)	V.S.W.R. in BW	Attenuation (dB) (MHz)	Marking
DFC22R44P084LHA	2442	fo ± 42	2.0	1.0	2.0	14 (fo + 250) 19 (fo - 250)	MT

### 2-POLE – GPS



### DIMENSIONS: mm

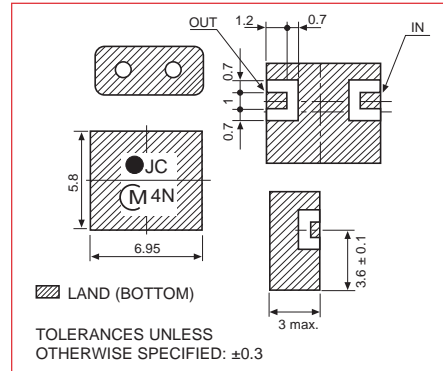

### TRANSMISSION vs. REFLECTION CHARACTERISTICS

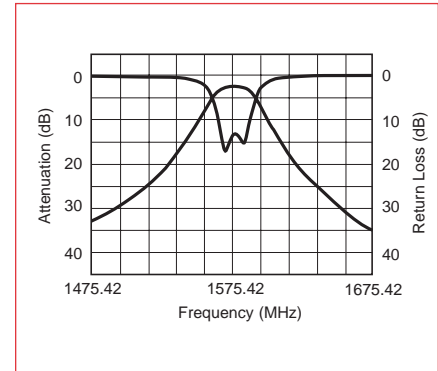

### SPECIFICATIONS

Part Number	Center Frequency $f_0$ (MHz)	Bandwidth (MHz)	Insertion Loss in BW (dB)	Ripple in BW (dB)	V.S.W.R. in BW	Attenuation (dB) (MHz)	Marking
DFC21R57P002HHA	1575.42	$f_0 \pm 1$	2.9 (0 ~ 35°C) 3.15 (-35 ~ 85°C)	0.5	2.0	18 ( $f_0 \pm 50$ )	JC

### 2-POLE – PCS UNLICENSED



### DIMENSIONS: mm

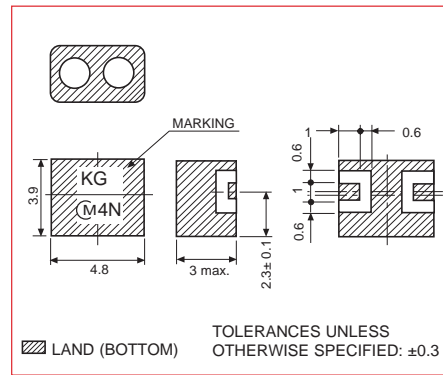

### TRANSMISSION vs. REFLECTION CHARACTERISTICS

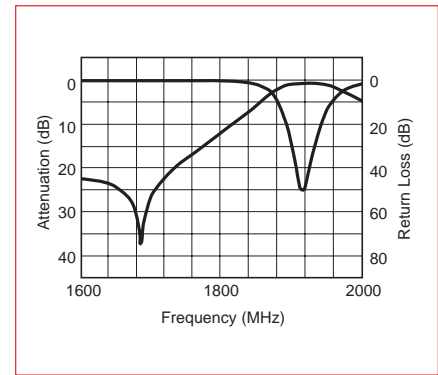

### SPECIFICATIONS

Part Number	Center Frequency $f_0$ (MHz)	Bandwidth (MHz)	Insertion Loss in BW (dB)	Ripple in BW (dB)	V.S.W.R. in BW	Attenuation (dB) (MHz)	Marking
DFC21R92P020HHD	1920	$f_0 \pm 10$	1.9	0.5	2.0	37 (1690 – 1710)	KG



#### 3-POLE—PCS/DCS 1800

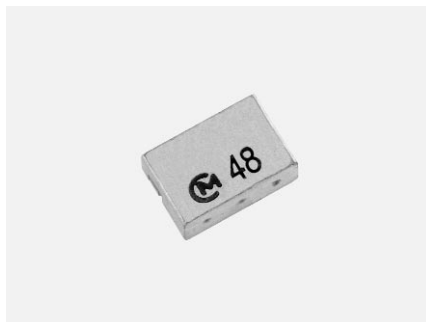

#### DIMENSIONS: mm

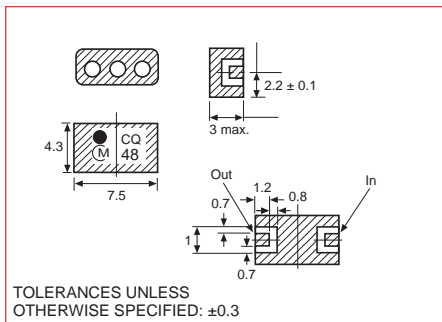

#### TRANSMISSION vs. REFLECTION CHARACTERISTICS (PCS)

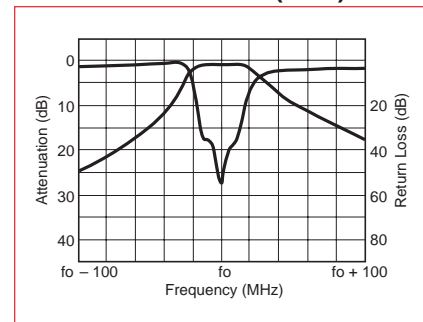

#### SPECIFICATIONS

Part Number	Center Frequency $f_0$ (MHz)	Bandwidth (MHz)	Insertion Loss in BW (dB)	Ripple in BW (dB)	V.S.W.R. in BW	Attenuation (dB) (MHz)	Marking
DFC31R88P060HHA	1880.0	$f_0 \pm 30$	2.4	1.0	2.0	10 ( $f_0 + 100$ )	CS
DFC31R96P060HHA	1960.0	$f_0 \pm 30$	2.4	1.0	2.0	18 ( $f_0 - 100$ )	CT
DFC31R74P075HHA	1747.5	$f_0 \pm 37.5$	2.8	1.6	2.0	7 ( $f_0 + 80$ )	CQ
DFC31R84P075HHA	1842.5	$f_0 \pm 37.5$	2.8	1.6	2.0	13 ( $f_0 - 80$ )	CR

#### 3-POLE—ISM 903/927



#### DIMENSIONS: mm

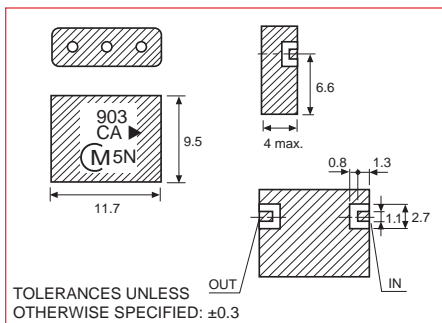

#### TRANSMISSION vs. REFLECTION CHARACTERISTICS

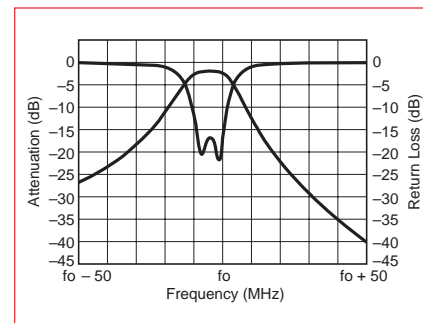

#### SPECIFICATIONS

Part Number	Center Frequency $f_0$ (MHz)	Bandwidth (MHz)	Insertion Loss in BW (dB)	Ripple in BW (dB)	V.S.W.R. in BW	Attenuation (dB) (MHz)	Marking
DFC3R903P002HHA	903	$f_0 \pm 1.0$	5.3	0.5	2.0	35 (925)	903 CA
DFC3R927P002HHA	927	$f_0 \pm 1.0$	5.3	0.5	2.0	29 (905)	927 CA

#### 3-POLE—PCS



#### DIMENSIONS: mm

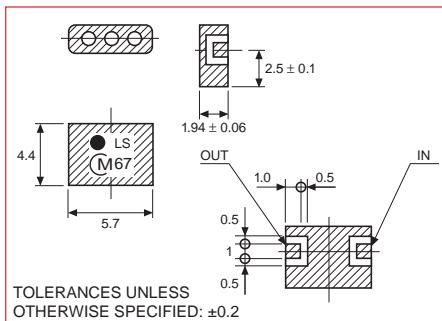

#### TRANSMISSION vs. REFLECTION CHARACTERISTICS

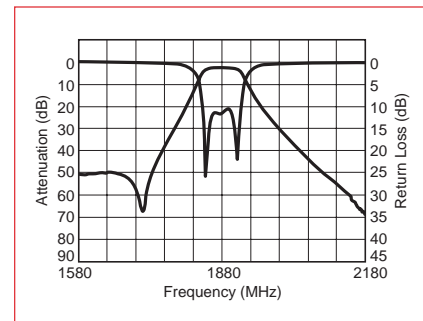

#### SPECIFICATIONS

Part Number	Center Frequency $f_0$ (MHz)	Bandwidth (MHz)	Insertion Loss in BW (dB)	Ripple in BW (dB)	V.S.W.R. in BW	Attenuation (dB) (MHz)	Marking
DFC31R88P060LHA	1880.0	$f_0 \pm 30$	3.7	2.0	3.0	43 (1640 ~ 1664)	LS
						25 (1770)	
						5 (1830)	
						5 (1930)	
						22 (1990)	
						43 (2096 ~ 2156)	

### 3-POLE—PCS



#### DIMENSIONS: mm

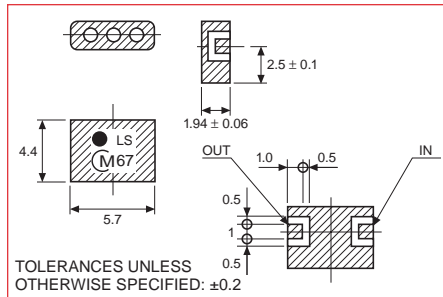

#### TRANSMISSION vs. REFLECTION CHARACTERISTICS

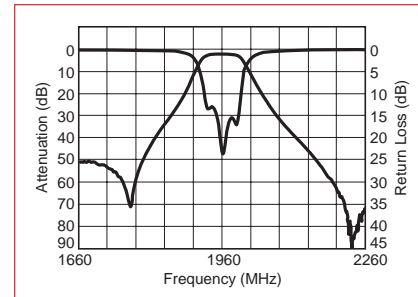

#### SPECIFICATIONS

Part Number	Center Frequency fo (MHz)	Bandwidth (MHz)	Insertion Loss in BW (dB)	Ripple in BW (dB)	V.S.W.R. in BW	Attenuation (dB) (MHz)	Marking
DFC31R96P060LHA	1960	fo ± 30	3.7	2.0	3.0	43 (1684 ~ 1744)	LT
						25 (1850)	
						5 (1910)	
						5 (2010)	
						22 (2070)	
						43 (2176 ~ 2236)	

### 3-POLE—PCS

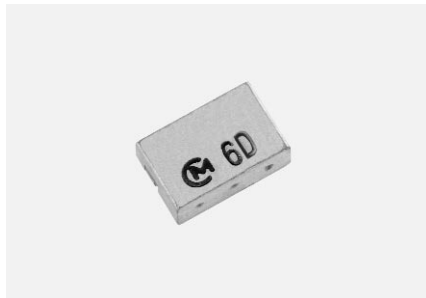

#### DIMENSIONS: mm

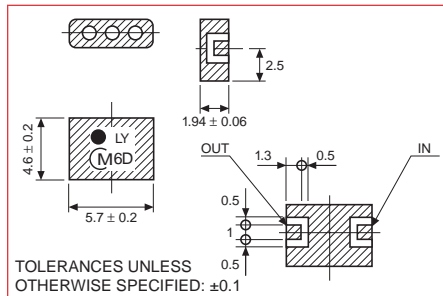

#### TRANSMISSION vs. REFLECTION CHARACTERISTICS

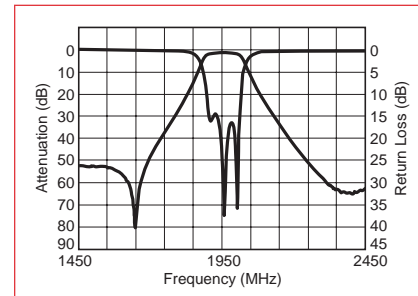

#### SPECIFICATIONS

Part Number	Center Frequency fo (MHz)	Bandwidth (MHz)	Insertion Loss in BW (dB)	Ripple in BW (dB)	V.S.W.R. in BW	Attenuation (dB) (MHz)	Marking
DFC31R96P060LHB	1960	fo ± 30	3.0	1.0	2.0	45 (1684 ~ 1744)	LY
						10 (1498 ~ 1860)	
						10 (2060 ~ 2360)	
						25 (2360 ~ 3000)	

### 3-POLE—E-AMPS/GSM/ISM 915



#### DIMENSIONS: mm

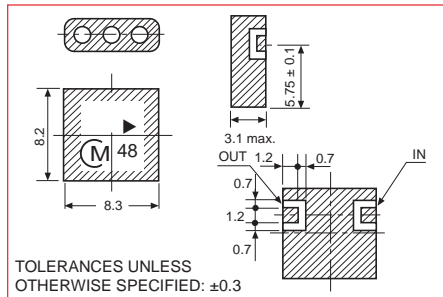

#### TRANSMISSION vs. REFLECTION CHARACTERISTICS

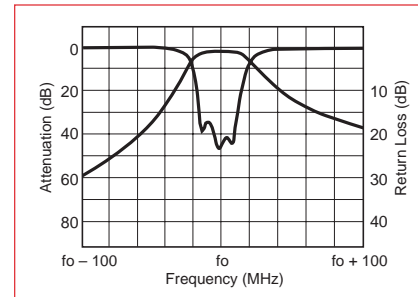

#### SPECIFICATIONS

Part Number	Center Frequency fo (MHz)	Bandwidth (MHz)	Insertion Loss in BW (dB)	Ripple in BW (dB)	V.S.W.R. in BW	Attenuation (dB) (MHz)	Marking
DFC3R836P025HHD	836.5	fo ± 12.5	3.0	1.0	2.0	12 (864 ~ 894)	836 CD
DFC3R881P025HHD	881.5	fo ± 12.5	3.0	1.0	2.0	15 (824 ~ 849)	881 CC
DFC3R915P026HHC	915.0	fo ± 13	3.0	1.0	2.0	12 (+32.5)	915 CF
						15 (-32.5)	
DFC3R902P025HHB	902.5	fo ± 12.5	2.6	1.0	2.0	12 (935 ~ 960)	902 CD
DFC3R947P025HHB	947.5	fo ± 12.5	3.0	1.0	2.0	.15 (890 ~ 915)	947 CE

#### MB TYPE/E-AMPS/GSM/ISM 915—2-POLE

DFC2R836P025HHD  
DFC2R881P025HHD  
DFC2R902P025HHD  
DFC2R947P025HHD  
DFC2R915P026HHE

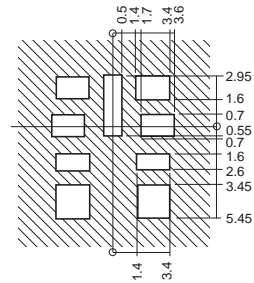
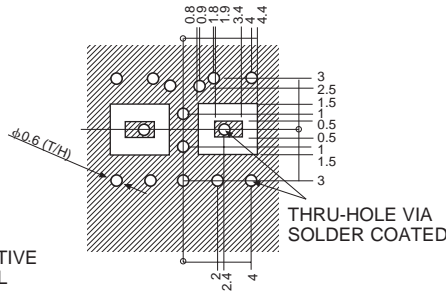

#### MB TYPE/E-AMPS/GSM/ISM 915—3-POLE

DFC3R836P025HHD  
DFC3R881P025HHD  
DFC3R902P025HHD  
DFC3R947P025HHD  
DFC3R915P025HHC

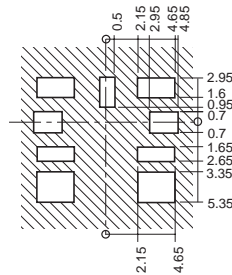
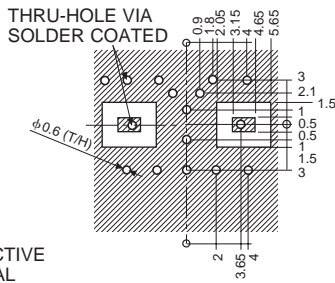

#### MB TYPE/GPS—2-POLE

DFC21R57P002HHA

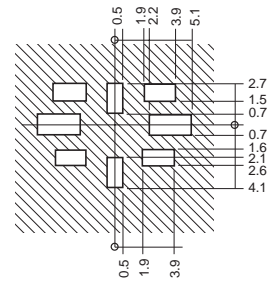
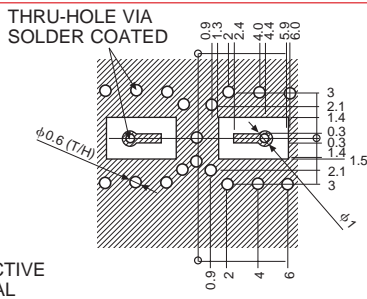

#### MB TYPE/PCS (UNLICENSED)—2-POLE

DFC21R92P020HHD

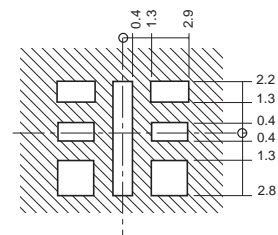
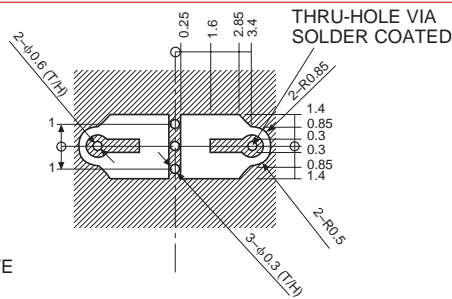

#### MB TYPE/ISM/903/927—2-POLE

DFC2R903P002HHA  
DFC2R927P002HHA

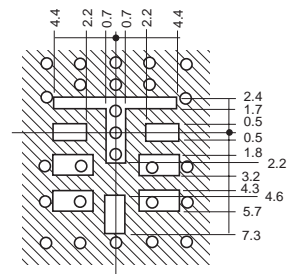
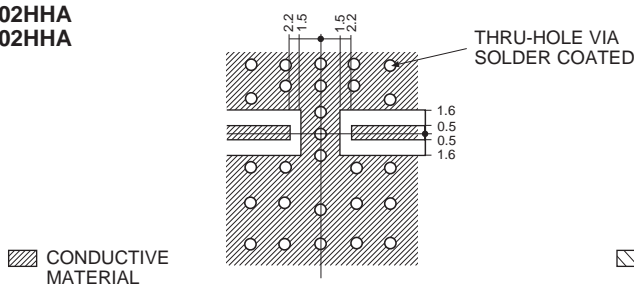

#### MB TYPE/PCS/DCS 1800—2-POLE

DFC21R88P060HHA  
DFC21R96P060HHA  
DFC21R74P075HHA  
DFC21R84P075HHA

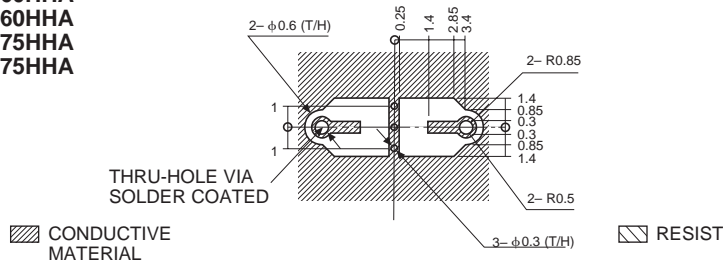

#### MB TYPE/2.4 ISM—2-POLE

DFC22R44P084LHA

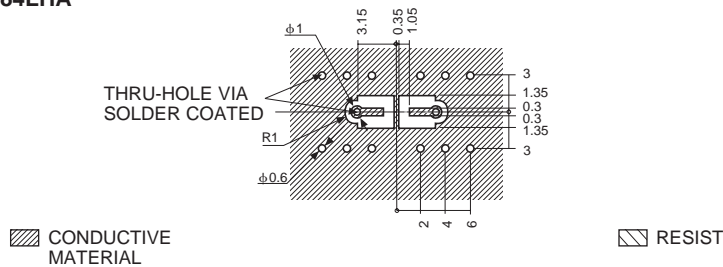

#### MB TYPE/PCS/DCS 1800—3-POLE

DFC31R88P060HHA  
DFC31R96P060HHA  
DFC31R74P075HHA  
DFC31R84P075HHA

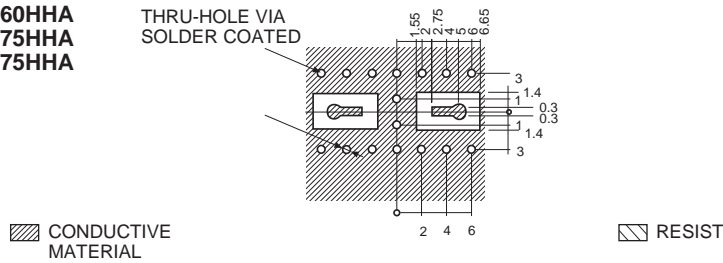

#### MB TYPE/PCS—3-POLE

DFC31R96P060LHB

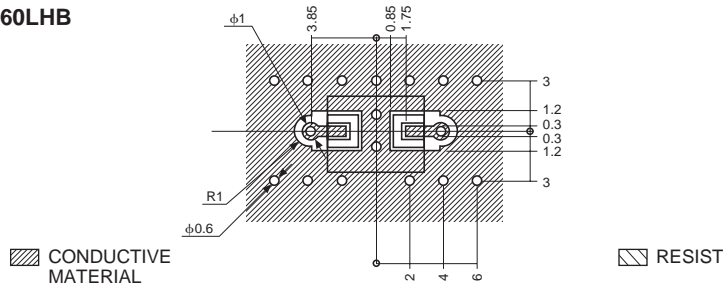

#### MB TYPE/PCS—3-POLE

DFC31R88P060LHA  
DFC31R96P060LHA

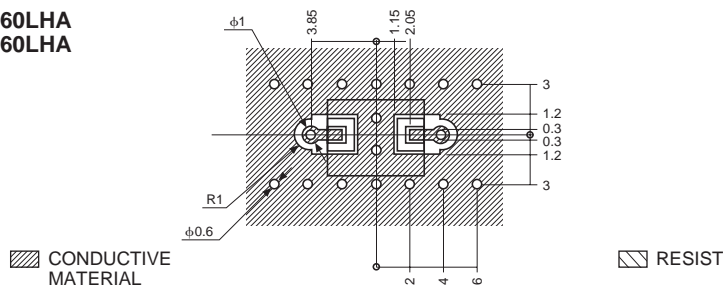

CERAMIC MICROWAVE FILTERS

# CERAMIC MICROWAVE FILTERS STANDARD LAND PATTERNS—BAND PASS FILTERS

## DP TYPE/PCS—4-POLE

DFC41R88P060BHX  
DFC41R96P060BHX

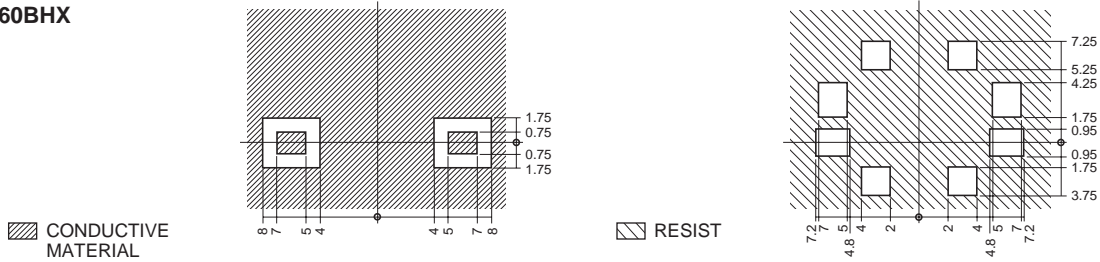

## MB TYPE/ISM—2-POLE

DFC2R903P002HHA  
DFC2R927P002HHA

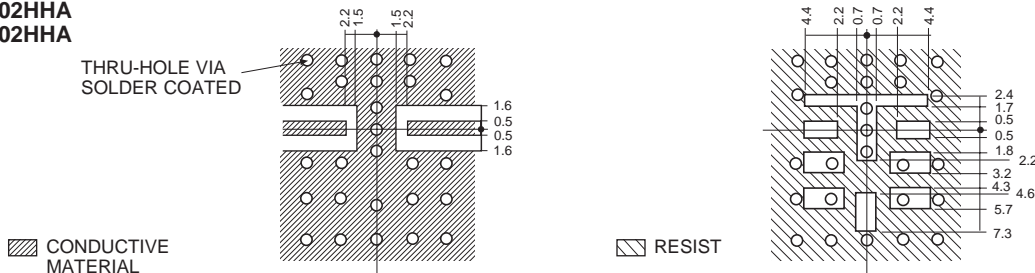

## MB TYPE/ISM 903/927—3-POLE

DFC3R903P002HHA  
DFC3R927P002HHA

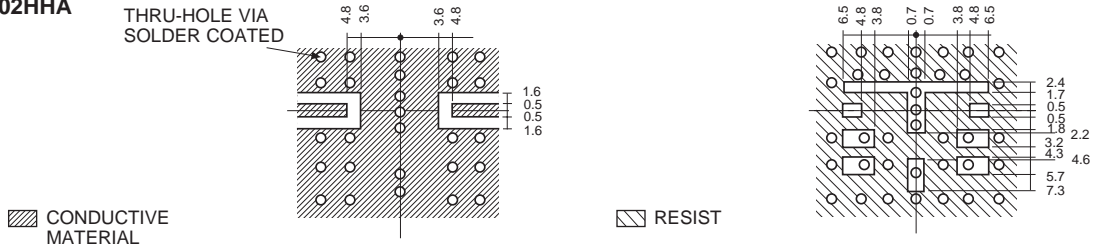

**Note:** Impedance of both input and output lines should be 50ohms including land pattern. The standard condition is applying glass epoxy board (dielectric constant = 4.8, copper metalized on both surfaces) and the input and output lines are connected to 50ohms microstrip lines on the back side surface through the via hole.

## ALSO AVAILABLE:

Application	Part Number	Marking
	2-Pole	
CT1	DFC2R914P001HHA	914 BB
	DFC2R959P001HHA	959 BB
	DFC2R886P002HHA	886 BB
	DFC2R931P002HHA	931 BB
PDC	DFC2R820P020HHA	JY
	DFC21R48P024LHA	PF
DECT	DFC21R89P020HHA	JR
CT2	DFC2RC866P004HHA	866 BB
PHS	DFC21R90P025LHA	MG
	DFC21R90P025LHB	NF
	DFC21R90P025LHC	NP

Application	Part Number	Marking
	3-Pole	
Cordless Phone	DFC3R914P001HHA	914 CB
	DFC3R959P001HHA	959 CB
	DFC3R886P002HHA	886 CB
	DFC3R931P002HHA	931 CB
CT2	DFC3R866P004HHA	866 CD
LMR	DFC3R815P019HHA	815 CC
	DFC3R860P019HHA	860 CE