





SMT Common Mode Chokes

1.22A to 14.0 A



-  Solutions based on impedance, size and current
-  Designed for DC/DC converters
-  Wide variety of inductor sizes and current ratings available
-  Dielectric strength: 1000V_{RMS}

Electrical Specifications @ 25°C - Operating Temperature -40°C to +120°C³

Part Number	Inductance (mH ±35%)	I _{rated} (A)	DCR (MAX) (mΩ)	Curve (see # below)	Package	Weight (Grams)	Quantity In Tube	Quantity In Reel
P0502NL	0.47	14.0	8	9	Big Foot	14.8	15	75
P0469NL	0.63	11.6	10	7	Big Foot	14.3	20	75
P0429NL	0.81	9.70	14	6	Big Foot	13.5	20	75
P0527NL	0.53	7.20	15	8	HCCI-68	7.7	15	100
P0353NL	0.59	5.60	21	7	LCCI-50	5.2	30	200
P0422NL	0.77	4.70	40	6	LCCI-50	4.9	30	200
P0421NL	0.22	3.30	60	5	LCCI-50	4.7	30	200
P0420NL	1.32	3.30	60	4	LCCI-50	4.6	30	200
P0351NL	1.47	2.80	80	3	LCCI-50	4.3	30	200
P0473NL	0.88	1.63	110	2	Polecat	1.5	35	500
P0354NL	1.17	1.22	200	1	Polecat	1.4	35	500

- Notes:**
- Optional Tape & Reel packaging can be ordered by adding a "T" suffix to the part number (i.e. P0502 becomes P0502T). Pulse complies to industry standard tape and reel specification EIA481.
 - The "NL" suffix indicates an RoHS-compliant part number. Non-NL suffixed parts are not necessarily RoHS compliant, but are electrically and mechanically equivalent to NL versions. If a part number does not have the "NL" suffix, but an RoHS compliant version is required, please contact Pulse for availability.
 - The temperature of the component (ambient plus temperature rise) must be within the stated operating temperature range.

Impedance Curves

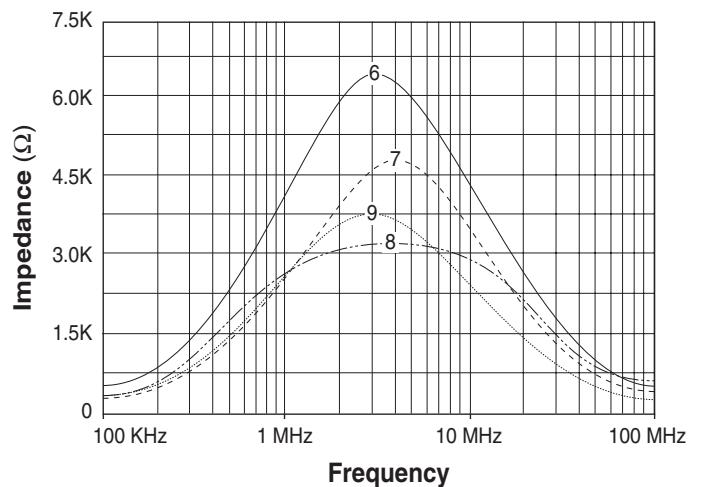
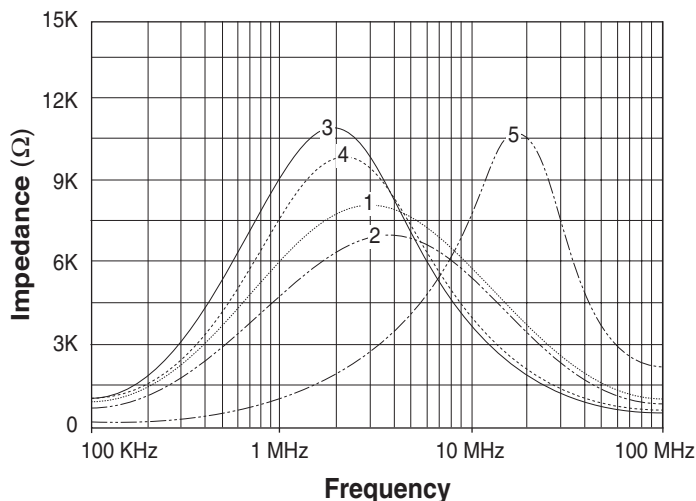

SMT Common Mode Chokes

1.22A to 14.0 A

Mechanicals

Polecat

LCCI-50

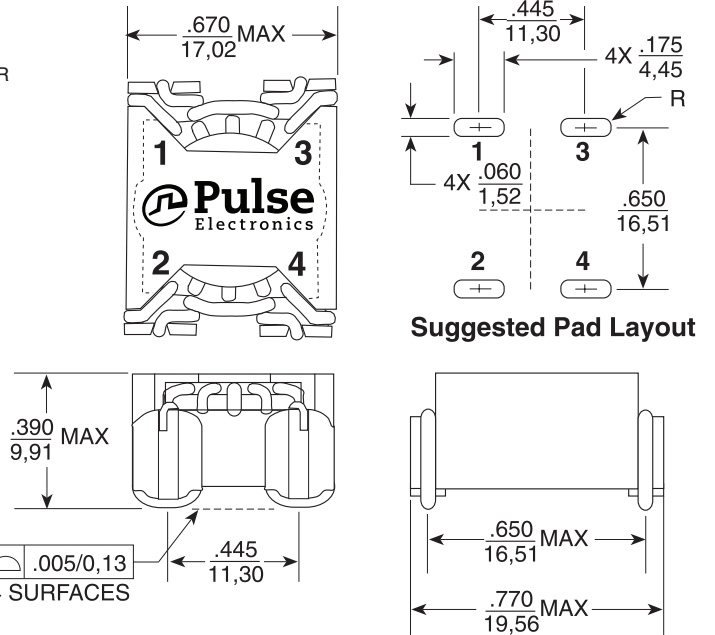
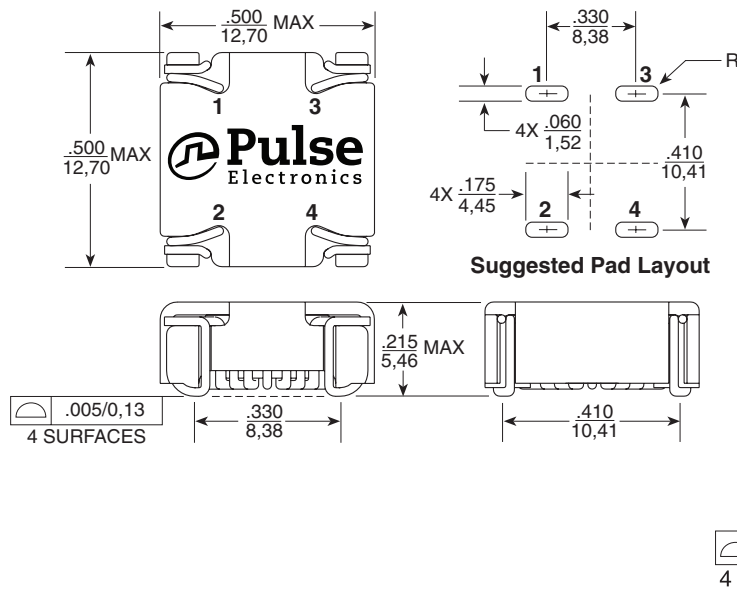

HCCI-68

Big Foot

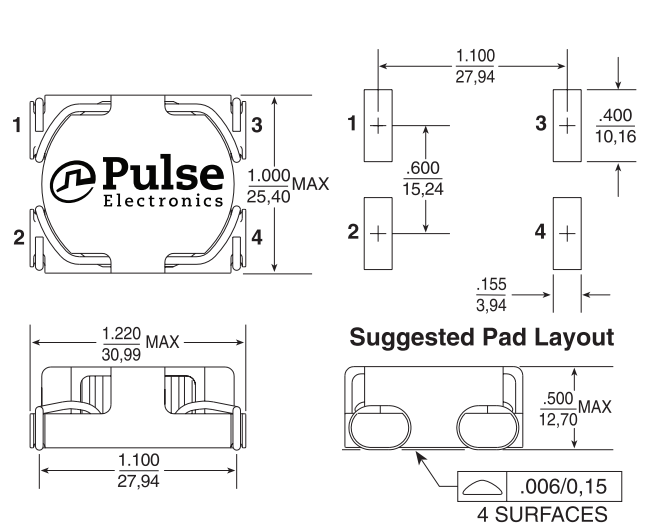
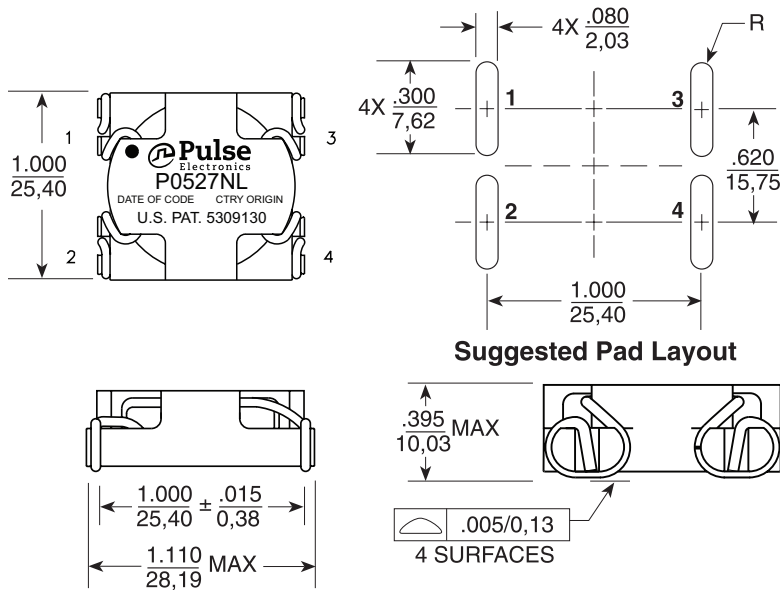

Schematic

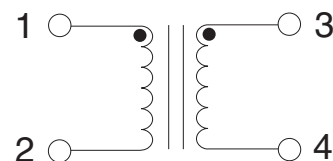

Dimensions: $\frac{\text{Inches}}{\text{mm}}$

Unless otherwise specified, all tolerances are $\pm \frac{.005}{0,13}$

Mouser Electronics

Authorized Distributor

Click to View Pricing, Inventory, Delivery & Lifecycle Information:

Pulse:

[P0420](#) [P0420T](#) [P0421](#) [P0421T](#) [P0422](#) [P0422T](#) [P0429](#) [P0429T](#) [P0469](#) [P0469T](#) [P0473](#) [P0473T](#) [P0502T](#)
[P0527](#) [P0527T](#) [P0351](#) [P0351T](#) [P0353](#) [P0353T](#) [P0354](#) [P0354T](#) [P0351NL](#) [P0354NLT](#) [P0422NLT](#) [P0354NL](#)
[P0429NL](#) [P0473NL](#) [P0527NL](#) [P0422NL](#) [P0351NLT](#) [P0421NLT](#) [P0421NL](#) [P0502NLT](#) [P0469NL](#) [P0502NL](#)
[P0353NL](#) [P0527NLT](#) [P0353NLT](#) [P0420NL](#) [P0420NLT](#) [P0429NLT](#) [P0469NLT](#) [P0473NLT](#)